



Shrink chucks 4,5° with coolant channels for mounting of solid carbide and HSS-tool shanks
Mandrins de frettage 4,5° avec canaux d'arrosage pour le serrage de queues d'outils en carbure du type HM et HSS

1



Verwendung:
Zur Aufnahme von Werkzeugen mit Zylinderschaft.

Application:
For mounting straight-shank tools.

Application:
Pour le serrage d'outil à queue cylindrique.

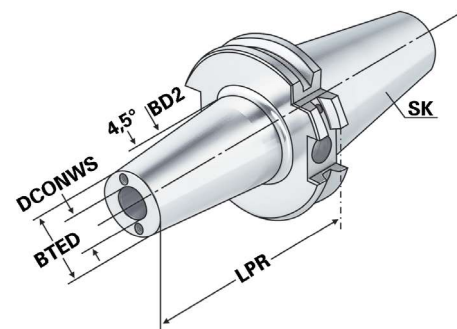

Bestell-Nr. Order no. Référence	SK	DCONWS	TDCON	LPR	BTED	BD2	LSCN	LSCX	ADJRGA	THID
403.70.06.K	SK 40	6	h6	80	21	27	22	36	10	M5x0,8
403.70.08.K	SK 40	8	h6	80	21	27	26	36	10	M6x1
403.70.10.K	SK 40	10	h6	80	24	32	31	41	10	M8x1
403.70.12.K	SK 40	12	h6	80	24	32	36	46	10	M10x1
403.70.14.K	SK 40	14	h6	80	27	34	36	46	10	M10x1
403.70.16.K	SK 40	16	h6	80	27	34	39	49	10	M12x1
403.70.18.K	SK 40	18	h6	80	33	42	39	49	10	M12x1
403.70.20.K	SK 40	20	h6	80	33	42	41	51	10	M16x1
403.70.25.K	SK 40	25	h6	100	44	53	47	57	10	M16x1
403.70.32.K	SK 40	32	h6	100	44	53	51	61	10	M16x1
403.70.06.1.K	SK 40	6	h6	120	21	27	22	36	10	M5x0,8
403.70.08.1.K	SK 40	8	h6	120	21	27	26	36	10	M6x1
403.70.10.1.K	SK 40	10	h6	120	24	32	31	41	10	M8x1
403.70.12.1.K	SK 40	12	h6	120	24	32	36	46	10	M10x1
403.70.14.1.K	SK 40	14	h6	120	27	34	36	46	10	M10x1
403.70.16.1.K	SK 40	16	h6	120	27	34	39	49	10	M12x1
403.70.18.1.K	SK 40	18	h6	120	33	42	39	49	10	M12x1
403.70.20.1.K	SK 40	20	h6	120	33	42	41	51	10	M16x1
503.71.06.K	SK 50	6	h6	80	21	27	22	36	10	M5x0,8
503.71.08.K	SK 50	8	h6	80	21	27	26	36	10	M6x1
503.71.10.K	SK 50	10	h6	80	24	32	31	41	10	M8x1
503.71.12.K	SK 50	12	h6	80	24	32	36	46	10	M10x1
503.71.14.K	SK 50	14	h6	80	27	34	36	46	10	M10x1
503.71.16.K	SK 50	16	h6	80	27	34	39	49	10	M12x1
503.71.18.K	SK 50	18	h6	80	33	42	39	49	10	M12x1
503.71.20.K	SK 50	20	h6	80	33	42	41	51	10	M16x1
503.71.25.K	SK 50	25	h6	100	44	53	47	57	10	M16x1
503.71.32.K	SK 50	32	h6	100	44	53	51	61	10	M16x1

LSCX = Einspannlänge, max.
 LSCX = Clamping depth, max.
 LSCX = Profondeur d'insertion, max.

ADJRGA = Verstellweg, max.
 ADJRGA = Length adjustment range, max.
 ADJRGA = Course de réglage, max.



Für Ø 3, 4 und 5 mm nur Hartmetallschäfte verwenden
 For Ø 3, 4 and 5 mm only solid carbide tool shanks must be used
 Pour Ø 3, 4 et 5 mm il faut seulement utiliser de queues d'outils en carbure du type HM